

PROPORTIONAL ELECTRO-HYDRAULIC RELIEF AND FLOW CONTROL VALVE

Dimensions

EFBG-03-125-CH

(With proportional pilot relief valve)

WEIGHT: 16 kg

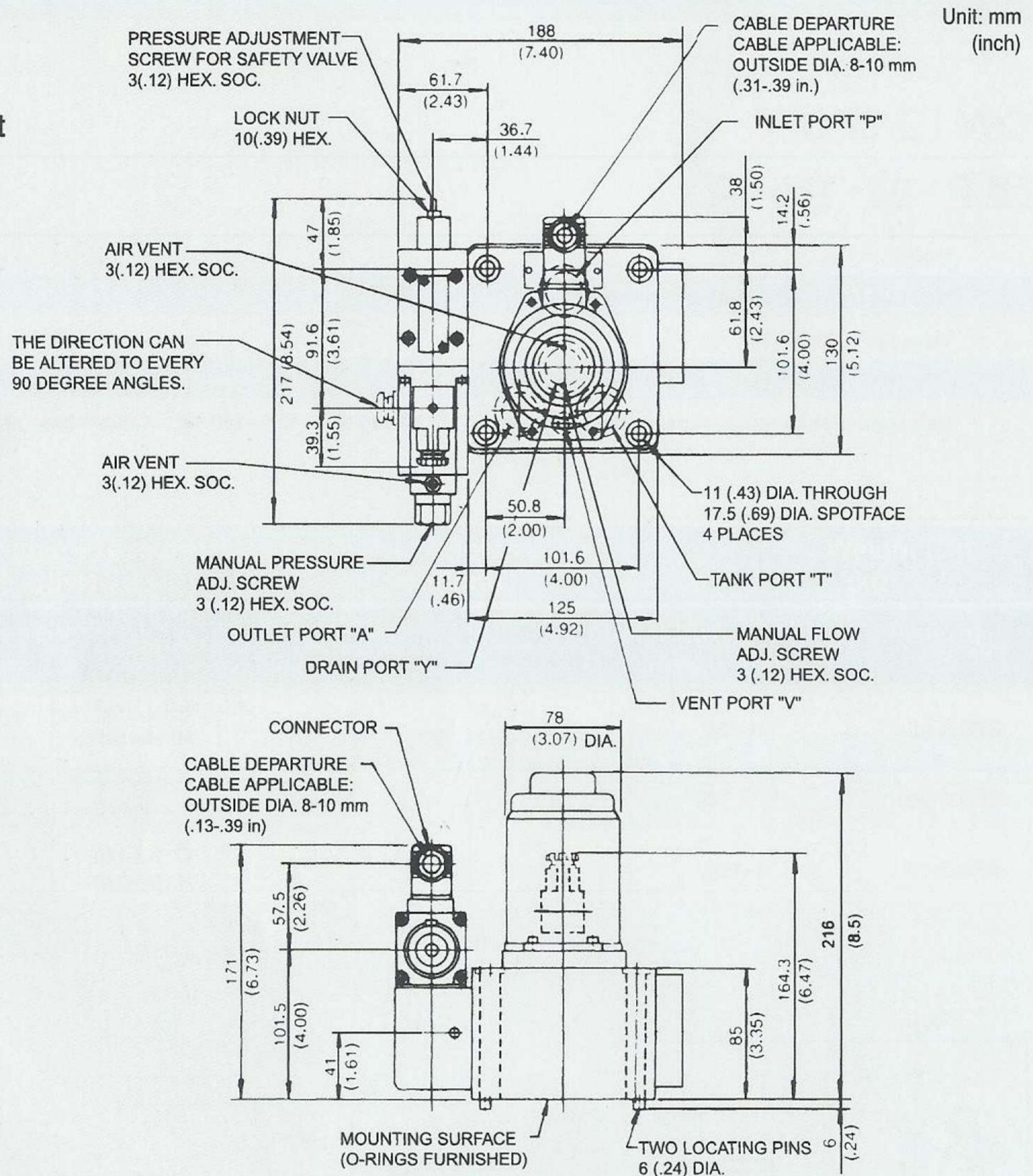

EFBG-03-125

(Without proportional pilot relief valve)

WEIGHT: 14 kg

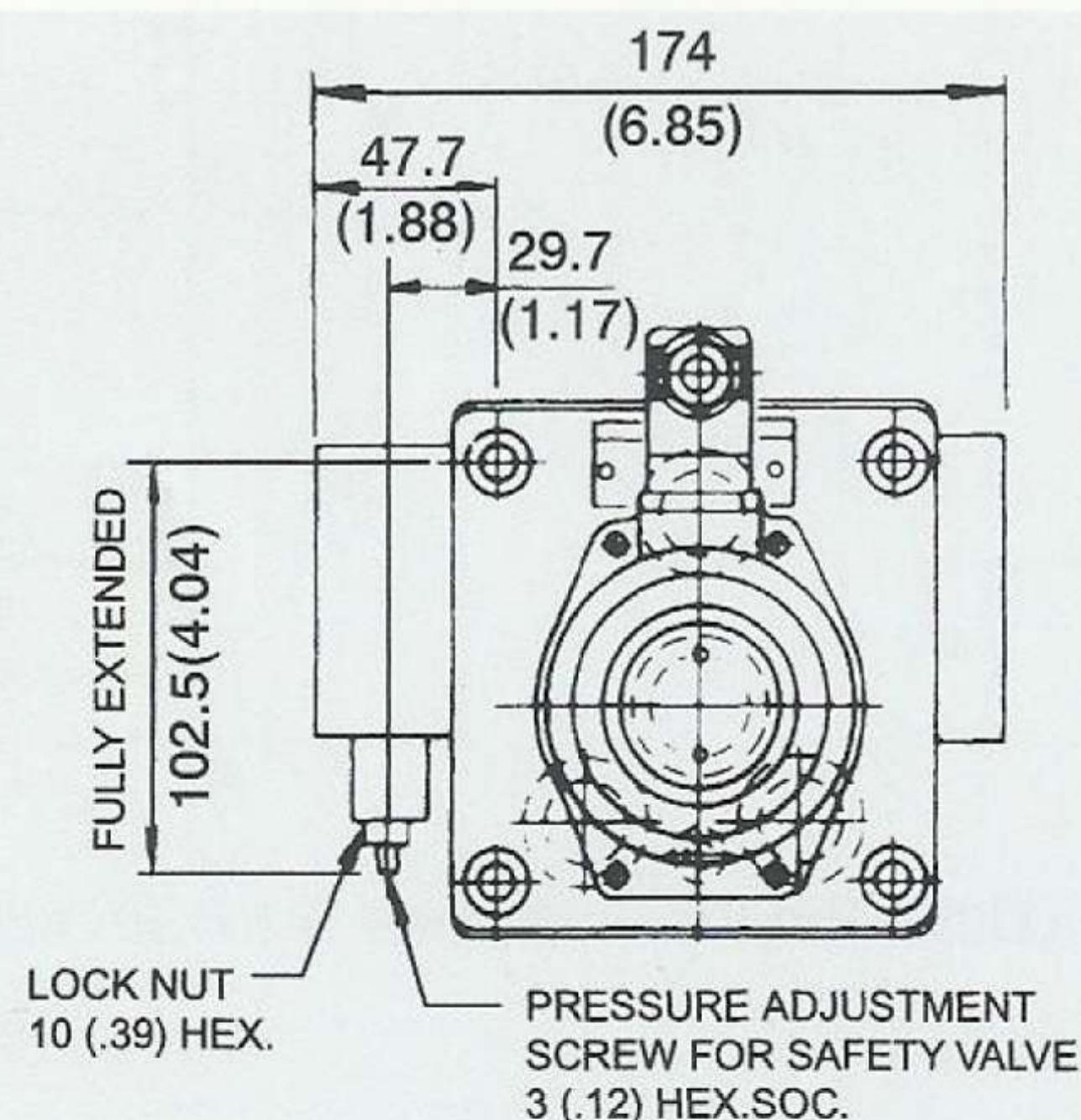

For other dimensions, please refer to the model above.

PROPORTIONAL ELECTRO-HYDRAULIC RELIEF AND FLOW CONTROL VALVE

Dimensions

EFBG-06-250-CH

(With proportional pilot relief valve)

WEIGHT: 30 kg

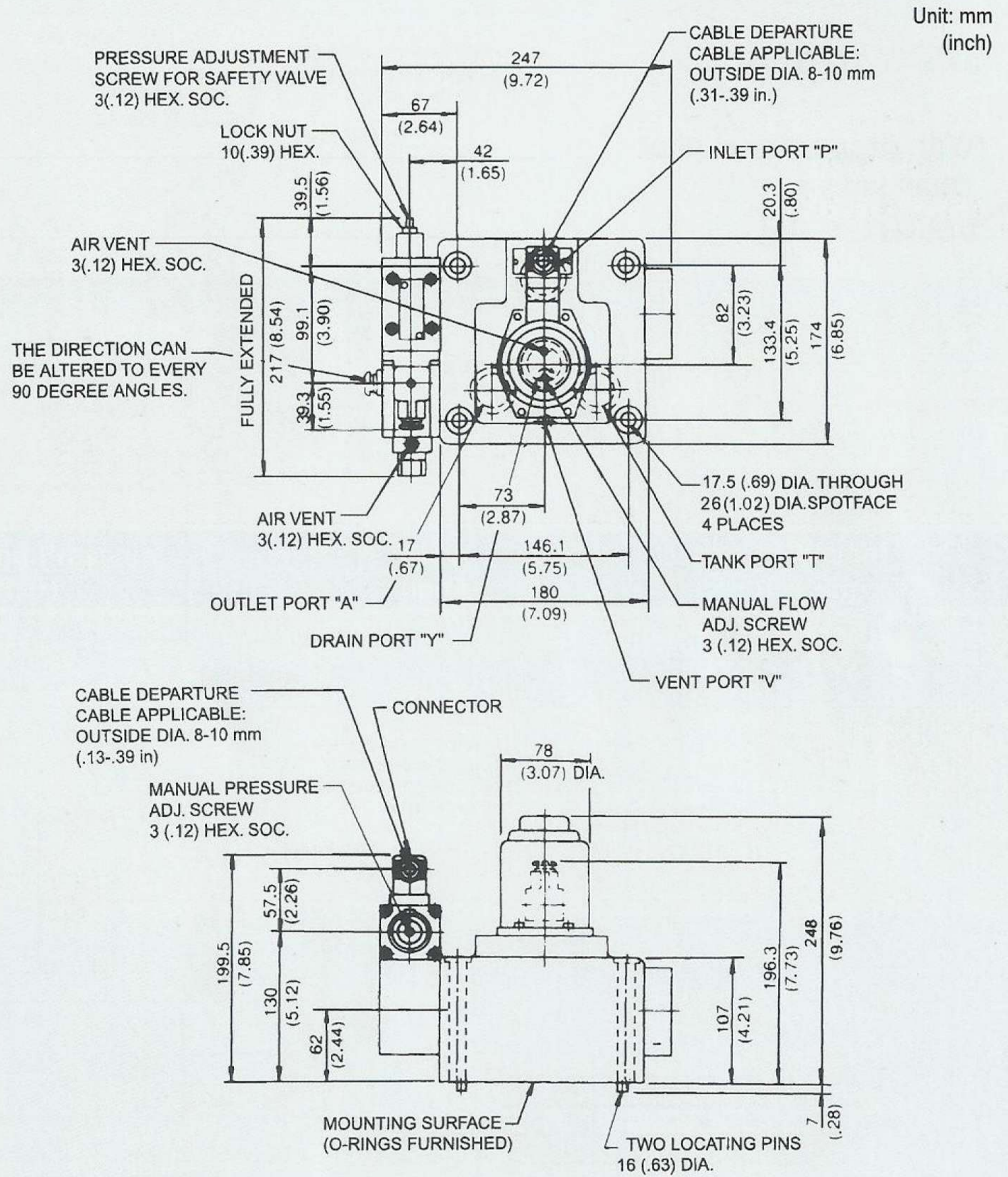

EFBG-06-250

(Without proportional pilot relief valve)

WEIGHT: 28 kg

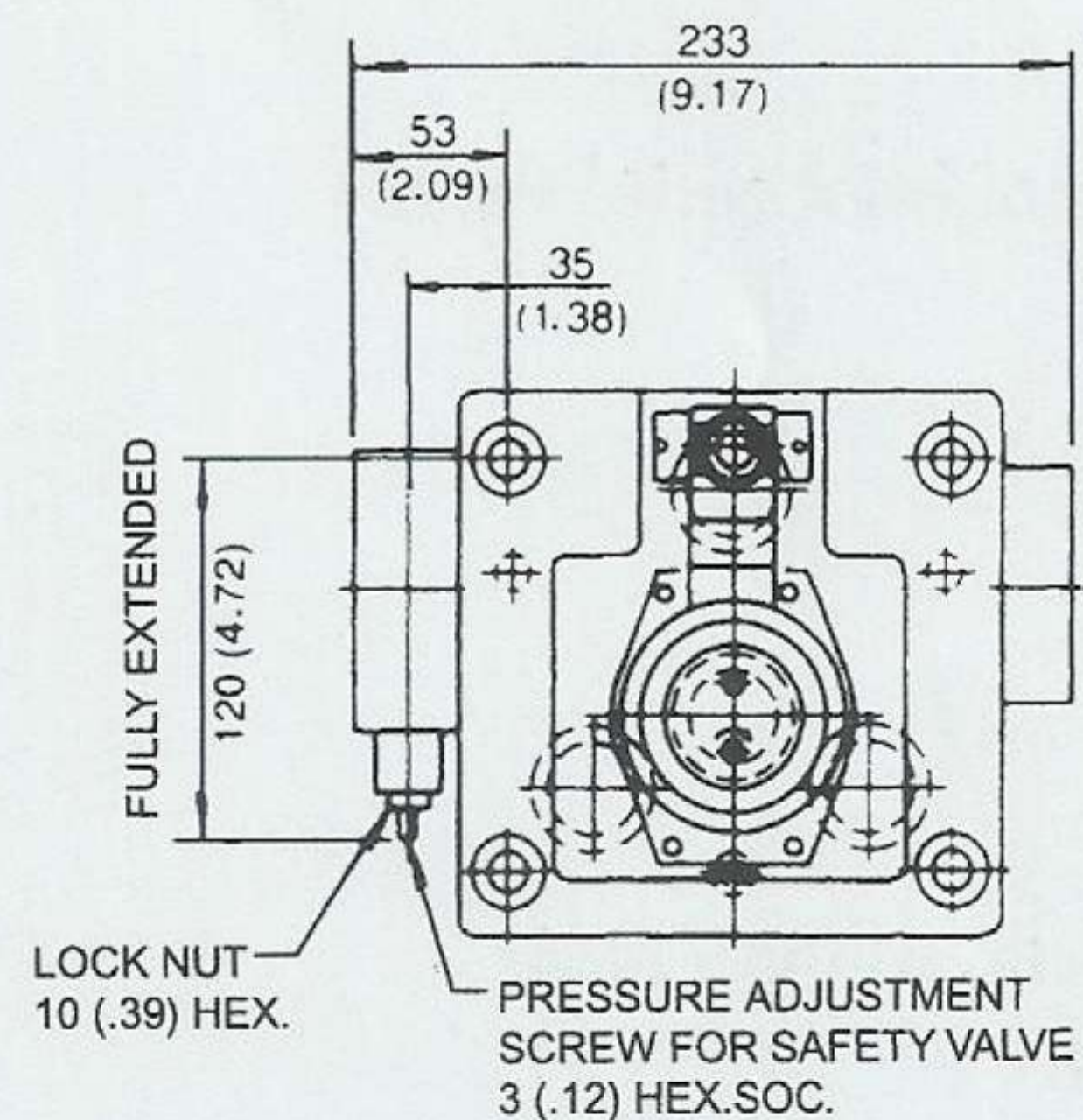

For other dimensions, please refer to the model above.

PROPORTIONAL ELECTRO-HYDRAULIC RELIEF AND FLOW CONTROL VALVE

Dimensions

EFBG-10-500-^C_H

(With proportional pilot relief valve)

WEIGHT: 60 kg

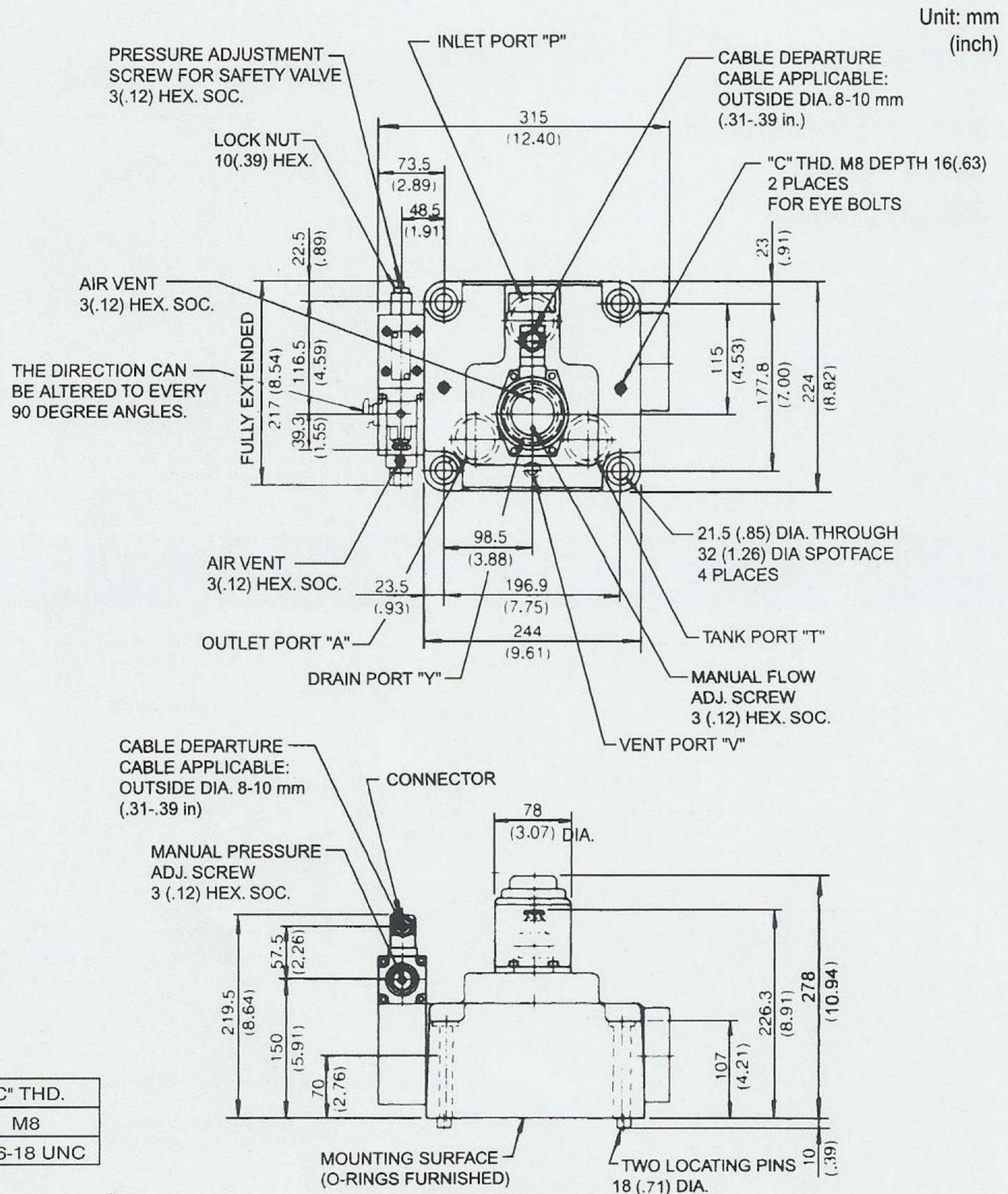

EFBG-10-500

(Without proportional pilot relief valve)

WEIGHT: 58 kg

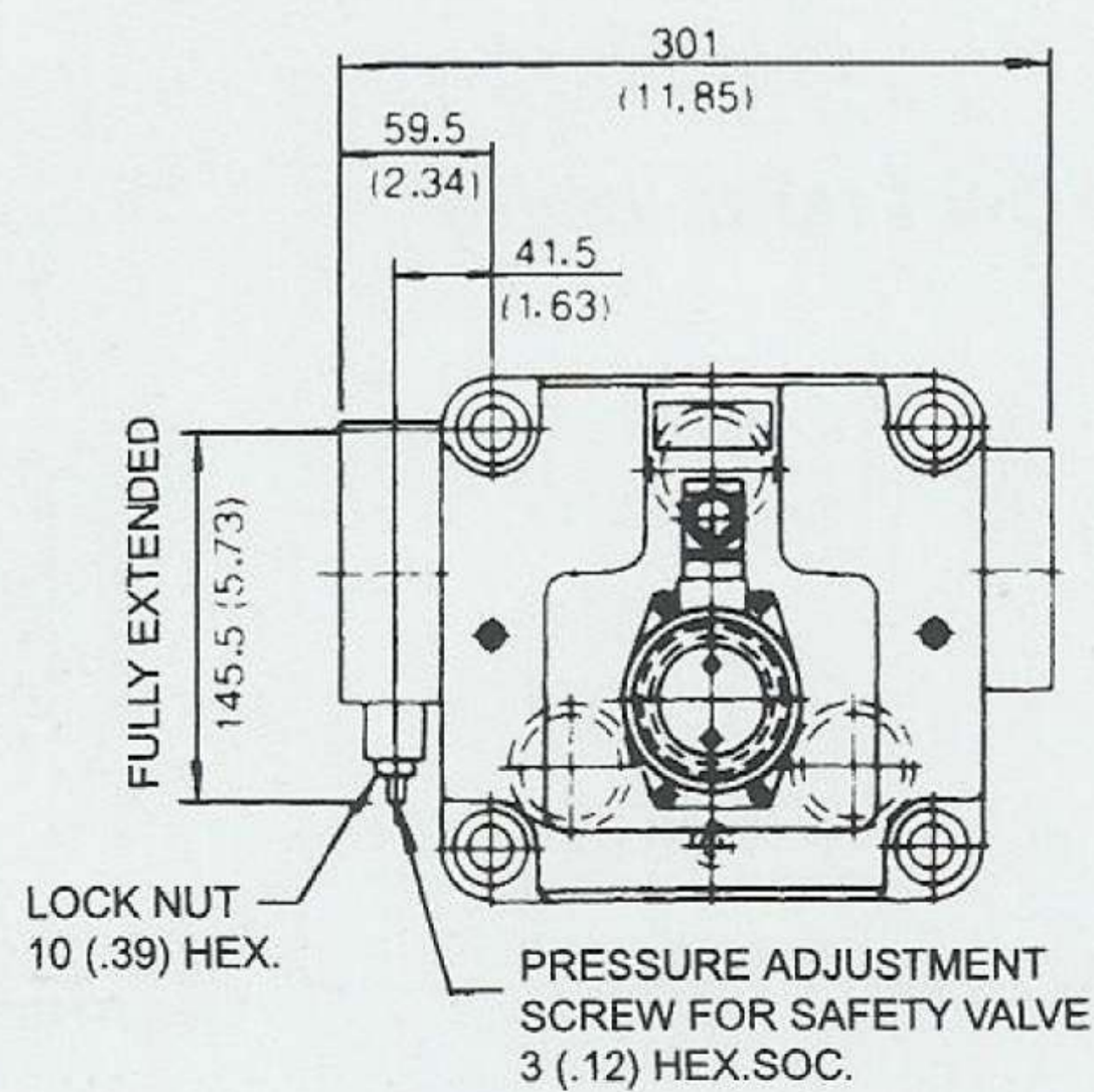

For other dimensions, please refer to the model above.

PROPORTIONAL ELECTRO-HYDRAULIC RELIEF AND FLOW CONTROL VALVE

FEATURES:

This relief and flow control valve is an energy-saving valve that supplies the minimum pressure and flow necessary for actuator drive.

Since this valve controls the pump pressure by following the load pressure while keeping the differential pressure mini-mized, it serves as a low power-consumption energy-saving, metre-in, controlled flow control valve.

Further, since a temperature compensation function is incorporated, this valve provides consistent flow control without respect to the fluid temperature.

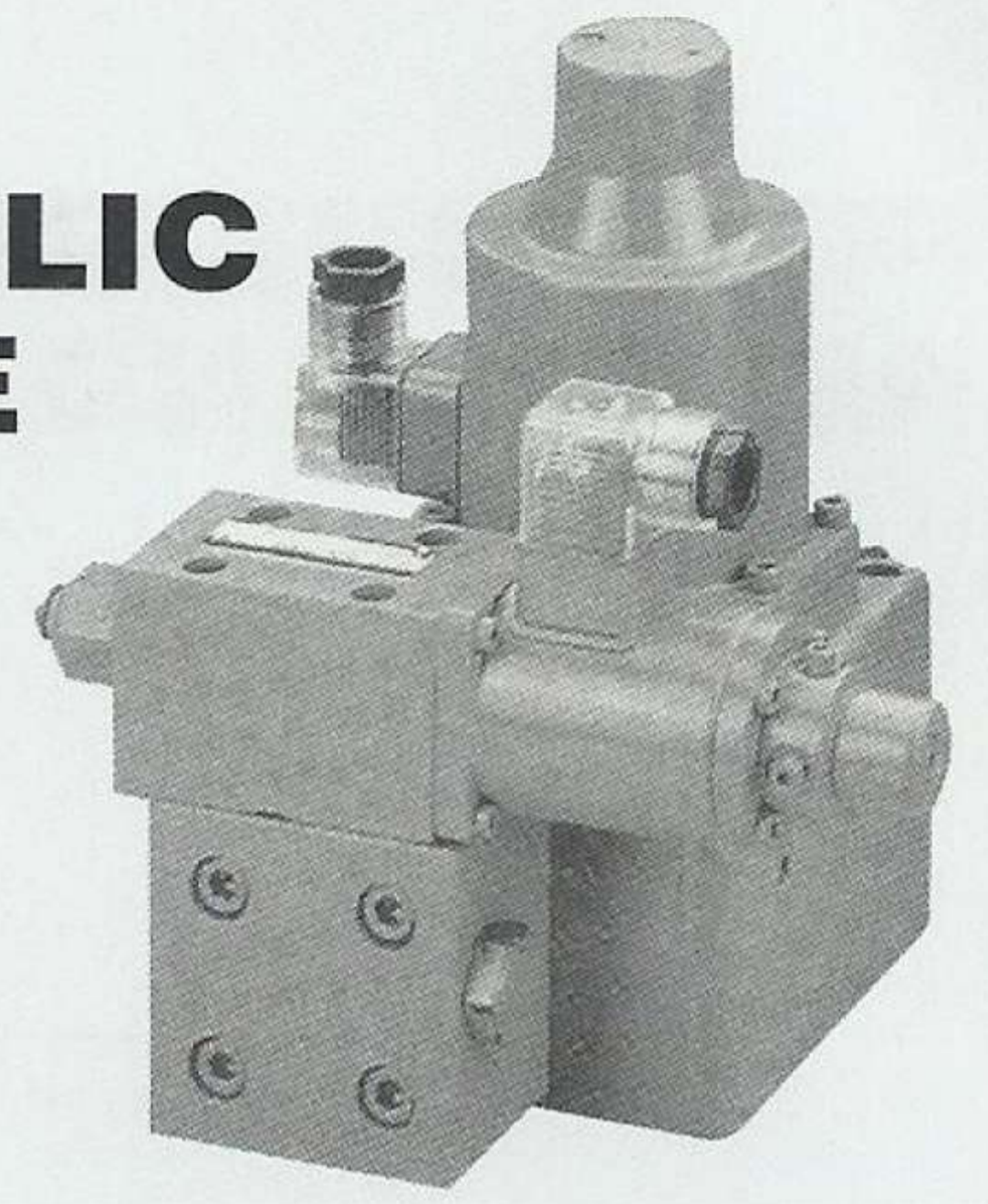

How to order

EFB G - 03 - 125 - C

1	2	3	4	5
1	Model			
2	Mounting type G: Sub-plate mounting			
3	Valve size 03, 06, 10			
4	Max. flow 03: 125 lpm 06: 250 lpm 10: 500 lpm			
5	With proportional relief valve pressure adjusting range C: 14-140 bar H: 14-210 bar Omit: Without proportional relief valve			

Specifications

Model	Flow Adj. Range (lpm)	Flow Controls			Pressure Controls			Weight (kg)
		Rated current (mA)	Coil Res. (Ω)	Diff. Press (bar)	Pressure Adj. Range(bar)	Rated current (mA)	Coil Res. (Ω)	
EFBG-03	1~125	680		6	C: 14~140 H: 14~210	C: 710 H: 770		18
EFBG-06	2.5~250	580	43.5	7	C: 15~140 H: 15~210	C: 690 H: 730	10	33
EFBG-10	5~500	700		9	C: 16~140 H: 16~210	C: 690 H: 690		58

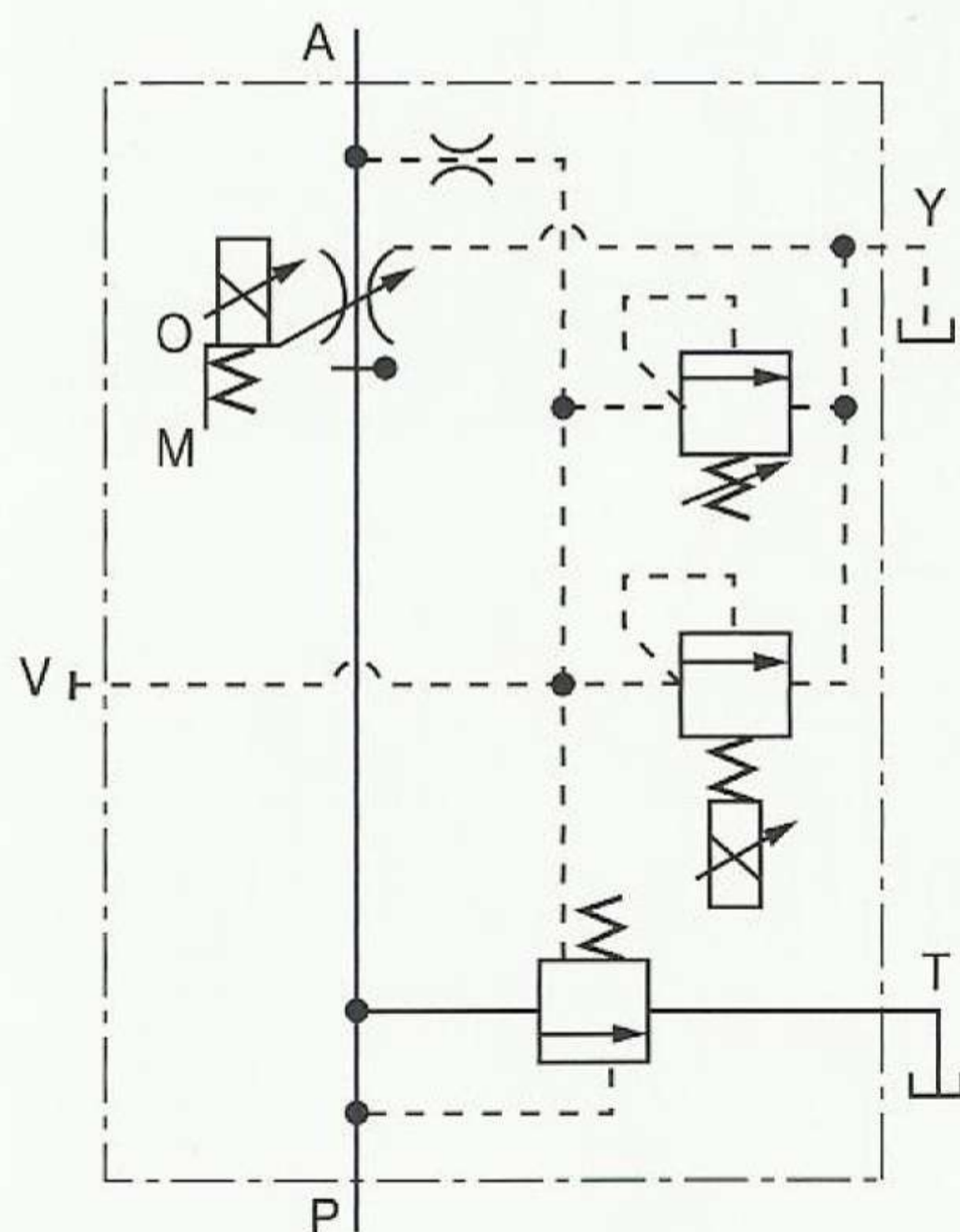

WITH PROPORTIONAL PILOT RELIEF VALVE

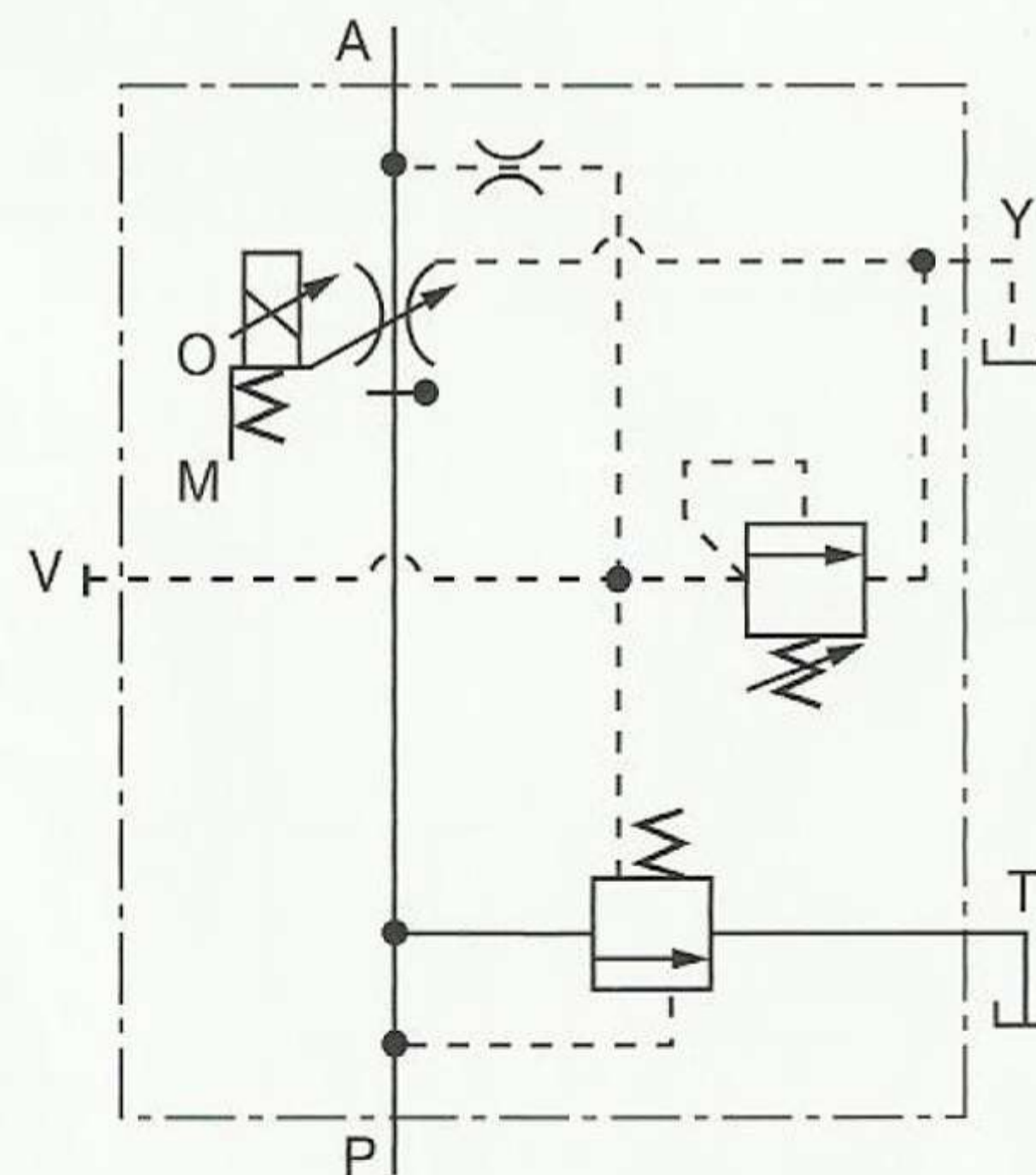

WITHOUT PROPORTIONAL PILOT RELIEF VALVE